

# BZ 103A

Setting tool for blind rivets

Pneumatic-hydraulic | with permanent and intermittent extraction

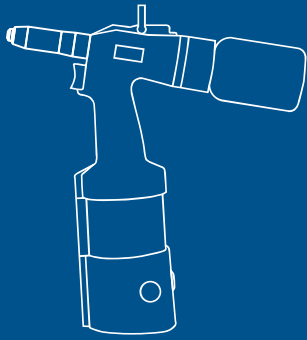

The **HONSEL BZ 103A** has been one of the most popular standard tools for reliable blind riveting up to 5 mm rivet diameter for years.

Users particularly appreciate the very **fast setting process** and the **outstanding ergonomics**, as well as the **low air consumption** and **reduced noise level**.

As with all **HONSEL** tools, it is supplied **complete with all the necessary conversion parts**. Extraction of the rivet mandrel can be **individually and precisely adjusted** to suit the particular application.

We will be happy to advise you on custom solutions tailored to your specific application.

## Reliable, robust, proven ten thousand times.



The air current holds the blind rivet securely in the nosepiece in any position before setting – one hand remains free to position the part.



Flat standard nosepieces with reduced dog point improve the setting behaviour and make the work process faster.

Family facts on the **HONSEL** pneumatic tools on page 65.

BZ 103A

	2.4	3.0	3.2	4.0	4.8	5.0	6.0	6.4	8.0
Aluminium	[Bar]								
Steel	[Bar]								
Stainless steel	[Bar]								
Copper alloys	[Bar]								
3.8 mm					11,700 N at 7 bar	G 1/4 inside thread, can be fitted on left or right			
1.8 kg					< 75 dB(A) (68.32)				
5-7 bar					• 1x pneumatic-hydraulic riveter BZ 103A in <b>HONSEL L-Boxx®</b>				
18 mm					• 4x nosepiece				
2.4 litres					• 1 set of clamping jaws				
					• 1 bottle of hydraulic oil with refill unit				
					• 2x mandrel collector				
<b>Item no. 320.103.000.000</b>									



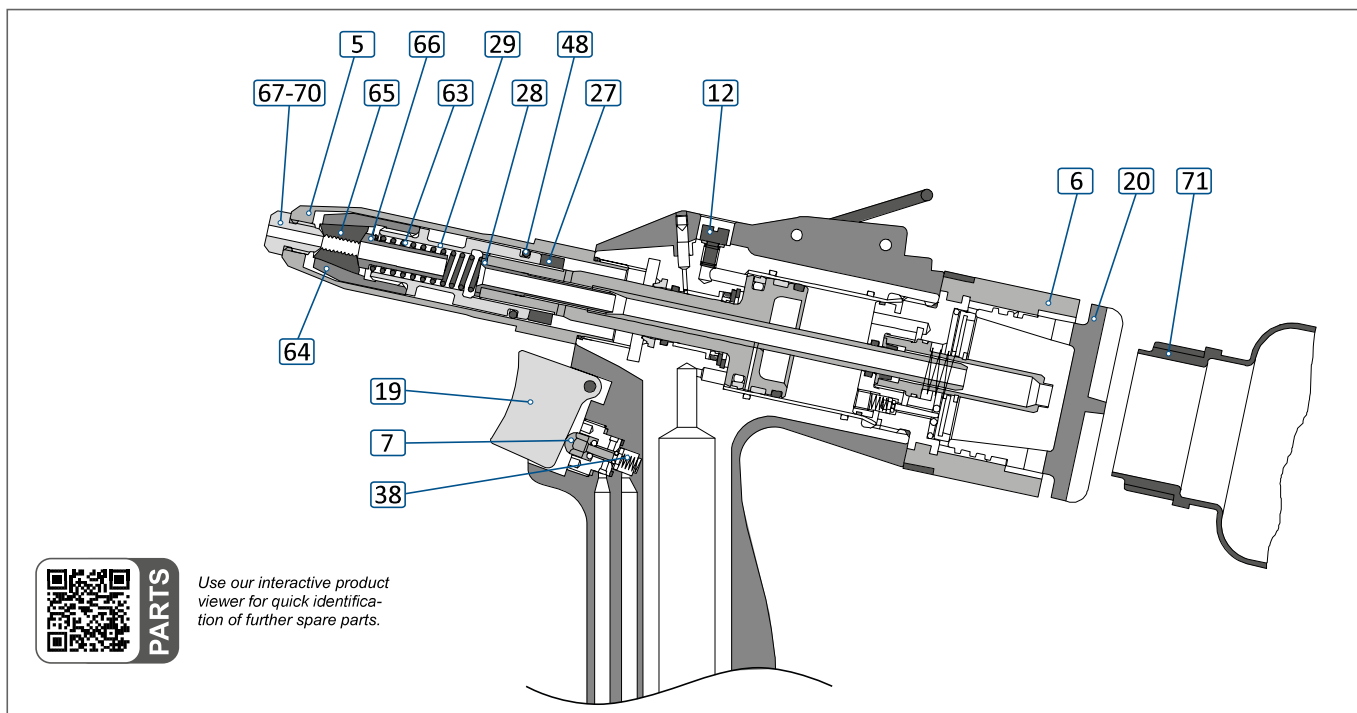

Use our interactive product viewer for quick identification of further spare parts.

### Spare / wear parts and accessories

5	321101000016	Front sleeve
6	321102000006	Mandrel capture comple
7	321102000007	Release valve
12	321101000027	Oil drain plug including o-ring
19	321102000016	Trigger
20	321102000017	Closing cap mandrel capture
27	321102000023	M12 x 3 capture nut
28	321121000121	Vacuum nozzle
29	321102000025	Spacer

38	321102000036	Pressure spring trigger
48	321101000042	O-ring 150 x 20 NBR 90° Shore
63	311045000013	Pressure spring clamping mechanism
64	311045000010	Clamping sleeve
65	321070000241	Clamping jaws (1 set = 3 pcs)
66	311055000020	Guide sleeve
71	321082000010	Mandrel collector
---	321101000091	Wind deflector to divert the mandrel suction air flow BZ tools

### Standard nosepieces

67	321070000240	Standard nosepiece 2.4 mm
68	321085000123	Standard nosepiece 3.0/3.2 mm
69	321085000124	Standard nosepiece 4.0 mm
70	321085000125	Standard nosepiece 4.8/5.0 mm

- ⚠ Special nosepieces can be produced at short notice for specific customer applications.
- ▶ Extended front sleeves and further accessories on pages 74 - 75.
- ▶ Pneumatic accessories on page 81.

### Special nosepieces

#### For recessed riveting points

Extended nosepieces 7 mm

321103932070	Extended nosepiece 3.0/3.2 mm
321103940075	Extended nosepiece 4.0 mm
321103950070	Extended nosepiece 4.8/5.0 mm

Extended nosepieces 20 mm

321103932200	Extended nosepiece 3.0/3.2 mm
321103940200	Extended nosepiece 4.0 mm
321103950200	Extended nosepiece 4.8/5.0 mm

Suitable for OPTO® multigrip blind rivets with extended mandrel.

#### For 5.0 mm large dome head blind rivets

321085000511	Facade nosepiece head 11.0 mm
321085000514	Facade nosepiece head 14.0 mm
321085000516	Facade nosepiece head 16.0 mm

#### For FERRO® BOLT 4.8 mm high-strength blind rivets

361101008401	Nosepiece FERRO®-BOLT 4.8 mm
--------------	------------------------------

#### For 5.2 mm folding blind rivets

321103716052	Nosepiece for folding blind rivets 5.2 mm
--------------	---

#### For burr-free setting of closed blind rivets

321085009124	CERTO® blind rivet 4.0 mm
321085009125	CERTO® blind rivet 4.8/5.0 mm